

# Safe-Hit<sup>®</sup> Delineator Post

## DELINEATORS



MASH

# Safe-Hit<sup>®</sup> Delineator Post

The Safe-Hit<sup>®</sup> Delineator Post is constructed of flexible and durable co-extruded polyethylene with ultraviolet inhibitors. It is self-certified as a NCHRP Report 350 and MASH Category 1 Device, and tested to NTPEP. It can be configured to MUTCD requirements for delineators or channelizing devices. The Safe-Hit<sup>®</sup> Delineator Post is ideal for roadside or lane line applications.

## ASSEMBLY AND MAINTENANCE

- Lightweight delineator post.
- Two piece, self-locking system helps reduce installation and replacement time.

## SPECIFICATIONS

- 18" to 54" High
- 2.25" Diameter
- 3" Width on Flattened Top Versions

## FEATURES

- Multiple base anchor options and portable bases.
- Surface mount bases ideal for asphalt or concrete.
- Soil anchors work in a wide range of soil types.
- Portable bases available in 18 lbs. and 32 lbs.
- Ultraviolet (UV) resistant post.
- Round post design can provide increased visibility in up to 360° direction.
- Standard post colors: white, yellow, and orange.
- Standard reflective colors: silver, amber, and orange.
- Custom colors available.
- Heights range from 18" to 54" above grade.

## SURFACE MOUNT, SOIL ANCHOR, OR GUARDRAIL POST TYPE

- Multiple configurations with either flat top or round top to fit various applications.

## SURFACE MOUNT BASE OPTIONS

- Surface mount pin lock base
- Surface mount twist lock base
- Sub-level twist lock base
- Sub-surface twist lock base
- Portable base

## SOIL ANCHOR OPTIONS

- Open end galvanized anchor
- Closed end galvanized anchor
- 8", 14", 18", and 24" anchor lengths available for different soil conditions.

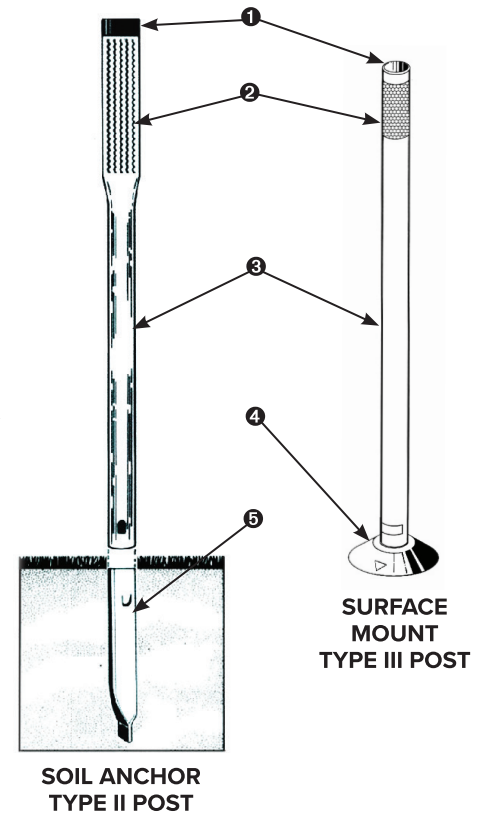
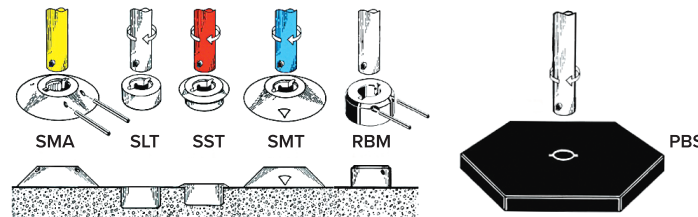

DISTRIBUTED BY

- 1 Cap
- 2 Reflective Sheeting
- 3 2.25" Polyethylene Tube
- 4 Surface Mount Base
- 5 Galvanized Soil Anchor