



PRODUCT CATALOG



TRINITY
HIGHWAY

Ahead of the Curve®



ABOUT SAFE-HIT®

The Safe-Hit® brand is the pioneer in state-of-the-art design and manufacture of products that delineate, direct, mark, indicate and instruct.

Since 1979, all Safe-Hit products have been manufactured and assembled in a dedicated manufacturing facility using high quality polymers and reflective materials. The brand offers numerous delineators in numerous sizes, lengths, shapes and colors, all tested to NTPEP standards.

Safe-Hit products include flexible soil and surface-mount posts, delineators, reboundable traffic channelizers, pedestrian devices, barricades, glare screens, and many additional specialty products. Product applications include public and private roadways, parking lots and parking structures, airports, and other facilities with traffic-management needs.

Trinity Highway is an industry leader and global supplier of commercial highway products. Our core product lines include guardrail, cable barrier, crash cushions, truck and trailer mounted attenuators, steel barriers, water-filled barricades, sign supports, and flexible delineators.

Through the collective acquisition of several premier brands including Energy Absorption, Safe-Hit, and Yodock, Trinity Highway is the modern day standard for innovation that will benefit future generations.



TABLE OF CONTENTS

MULTI-PURPOSE SYSTEMS

SAFE-HIT® DELINEATORS, CHANNELIZERS & MARKERS

Safe-Hit Delineator Posts	03
Soil Anchored Systems	04
Accessories & Tools	05
Surface Mounted Systems	06
Adhesives & Accessories	07
Twister® Base Products	08-09
Safe-Hit SQR-LOC® Flexible Delineator	10-11

HIGH PERFORMANCE SYSTEMS

DURA-POST® DELINEATORS, CHANNELIZERS & MARKERS

Dura-Post High Performance System	13
Dura-Post Options.....	14
Dura-Post SX High Performance Delineator	15

Dura-Post Anchors, Bases & Accessories	16
Rubbertough 360 (RT 360).....	17
Dura-Post Vertical Sign Panels	18-19
Reflective Decals & Sheeting	20-21

SPECIALTY PRODUCTS

Safe-Hit Sign Posts	23
Safe-Hit Sno-Post™ Boundary Markers.....	24
Safe-Hit Certified Airport Markers	25
Guardrail Delineators	26
KonaPost® Quick Change Delineators.....	27
Dura-Post Island K-Markers.....	28
Speed Bumps & Parking Stops.....	29
Safe-Hit GlareScreen.....	30-31

YOU CHOOSE

Choose between the Standard or High Performance model of our delineator posts and channelizers.

STANDARD. Our Standard products are our multi-purpose Safe-Hit posts. Safe-Hit's flexible 2.25" (57.2mm) diameter posts are available with portable bases, surface mount bases or soil anchors. Safe-Hit posts feature a two piece, self-locking system that reduces installation and maintenance costs. The Safe-Hit line is ideal for applications with average impact frequency.

HIGH PERFORMANCE. The Dura-Post line is our High Performance, long life delineators. Dura-Post's 3" (76.2mm) diameter delineators are composed of extremely flexible specialty polymer with excellent rebound memory. They are designed for areas with very high-impact frequency and have been successfully tested to withstand over 200 impacts at 60 mph. The posts remain flexible even at extreme temperatures. The Dura-Post line is ideal for sites with extreme environments and an excessive number of impacts.



Safe-Hit® Delineators, Channelizers & Markers



SAFE-HIT® DELINEATOR POSTS

The Safe-Hit® Delineator Post is constructed of flexible and durable co-extruded polyethylene with ultraviolet inhibitors. It meets the requirements of NCHRP Report 350 Category 1 Devices, has been NTPEP tested, and meets MUTCD requirements. Safe-Hit is ideal for applications with average impact frequency.

FEATURES

- Multiple base anchor options and portable bases available.
- Surface mount bases are ideal for asphalt or concrete.
- Soil anchors work in a wide range of soil types.
- Portable bases available in 18 lbs. & 32 lbs.
- Ultra-violet resistant.
- 360° visibility
- Standard colors: white, yellow and orange.
- Heights range from 18" - 54" above grade.
- Custom colors available.

ASSEMBLY AND MAINTENANCE



- Lightweight.
- Two piece, self-locking system reduces installation efforts.
- Quick and easy removal and replacement when needed.

SPECIFICATIONS

- 18" to 54" high
- 2.25" Diameter / 3" Width on Flattened Top Versions

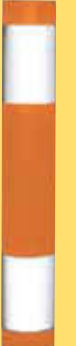

SOIL ANCHOR & SURFACE MOUNT POST TYPES

				
	TYPE 1	TYPE 2	TYPE 3	TYPE 5
	Hazard (Flat)	Guide (Flat)	Channelizer	Marker
	Round post, flattened on top with black oval cap, three 3" (76.2 mm) x 3" (76.2 mm) reflective patches, Driveable Soil Anchor and Surface Mount Pin Lock Base.	Round post, flattened on top with black oval cap, one 3" (76.2 mm) x 9" (228.6 mm) reflective strip, Driveable Soil Anchor and Surface Mount Pin Lock Base.	Used for a low profile due to traffic, round post with recessed cap, one 6" (152.4 mm) reflective wrap, Driveable Soil Anchor and Surface Mount Pin Lock Base.	Ideal for periodic removal and installations, round post with recessed cap, two 3" (76.2 mm) reflective wraps, Drivable Soil Anchor and Surface Mount Pin Lock Base.
Soil Anchor	54", 48", 42", 36", 28", 24" SH148GP3 Series	54", 48", 42", 36", 28", 24"	54", 48", 42", 36", 28", 24"	54", 48", 42", 36", 28", 24"
Surface Mount	54", 48", 42", 36", 28", 24" SH148SMA Series	54", 48", 42", 36", 28", 24", 18" SH248SMA Series Meets MUTCD 3F .02	54", 48", 42", 36", 28", 24", 18" SH348SMA Series Meets MUTCD 3F .63	54", 48", 42", 36", 28", 24", 18" SH548SMA Series Meets MUTCD 3F .65

SOIL ANCHORED SYSTEMS

Safe-Hit's® two-part driveable delineators feature a 2-1/4" (57.2 mm) post diameter and are used for marking highways, entrances, exits, curves, driveways, fire lanes and parking lots. Decals can be used instead of reflective sheeting if desired. Each post includes one 14" (355.6 mm), 18" (457.2 mm) or 24" (609.6 mm) closed or open end soil anchor.



POST OPTIONS

- Standard post colors: white, yellow or orange
- Custom colors: light gray, dark gray, green, blue, black, brown or red
- Reflective sheeting: Standard is High Intensity Flexible Prismatic silver, amber or orange

SOIL ANCHOR OPTIONS

Safe-Hit's drivable posts come standard with an 18" (457.2 mm) closed end, drivable Soil Anchor. You may substitute other anchor sizes. In heavy soil a 14" (355.6 mm) or 18" (457.2 mm) anchor is recommended. In sandy or loose soil a 24" (609.6 mm) anchor should be utilized. The 8" (203.2 mm) anchor is used for concrete applications.

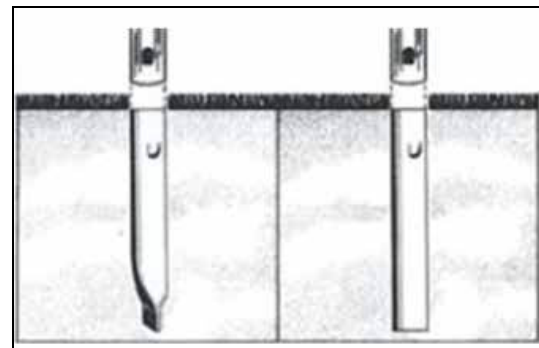

Closed End Soil Anchor Open End Soil Anchor

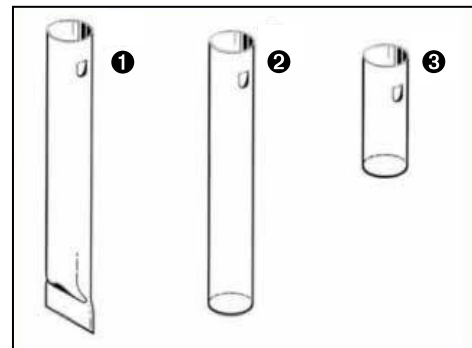

- 1 14", 18" or 24" Closed End Soil Anchor
- 2 14", 18" or 24" Open End Soil Anchor
- 3 8" Open End Concrete Anchor



ACCESSORIES & TOOLS

MANUAL INSTALLATION TOOLS

MANUAL ANCHOR INSTALLATION TOOL

The manual installation tool drives anchors into the soil. Designed to maintain the correct inside diameter and shape of the installed soil anchor.

Part No. SHTOL-30-6-X

ANCHOR STRAIGHTENING TOOL

Used to straighten anchors installed out of plumb.

Part No. SHTOL-60--ST



POST REMOVAL TOOL

Post maintenance slotted T-Bar tool aides in the removal of posts from anchors.

Part No. SHTOL-61--MT

MAINTENANCE KIT

Includes cutting tool, replacement blade, adjustable hacksaw and channel pliers. These tools are used to remove broken or damaged posts from anchors.

Part No. SHTOL-50--MT

POWER INSTALLATION TOOLS

JACKHAMMER

If using a jackhammer, order a jackhammer shank and an SH6 tool.

CYLINDER HAMMER

If using a piston cylinder hammer, order an adapter drive cap and an SH6 tool.

SHANKS

Part #	Tool	Size
SHTOL-07--HT	Pionjar	7/8" x 41/4"
SHTOL-53--HT	Stanley	7/8" x 31/4"
SHTOL-54--HT	Thor	1" x 41/4"
SHTOL-55--HT	Bosch	1-1/8" x 6"
SHTOL-56--HT	Ingersol	1-1/4" x 6"

ADAPTER DRIVE CAP

SHTOL-57--HT	Stanley	PD-45
SHTOL-58--HT	Fairmont	H4825C
SHTOL-59--HT	Rhino	PD-50



PILOT HOLE TOOL

Self-cleaning pilot hole tool for use with power equipment to provide pilot holes for Safe-Hit soil anchors in compacted or adverse soils. Requires drive shank or ADAPTER for specific power tool used.

Part No. SHTOL-08--HT

SH6 DRIVE TOOL

Interface from shanks and/or adapters to soil anchor (always needed)

Part # SHTOL-06--HT

SOIL ANCHOR

(ordered separately)

More shanks and adapter drive caps are available to fit your specific power tool. Call for details.

SOIL MOUNT ACCESSORIES

	"O" Ring Replacement Black for all soil anchor posts.
	Oval Cap for Type 1 and Type 2 Posts. Available in black, white, yellow, dark gray, light gray, yellow-green.
	Anchor Plug for all soil anchors. Available in black (BL), orange (OL),



SURFACE MOUNTED SYSTEMS

Safe-Hit® surface mount channelizers and tubular markers are easy to install and come standard with a convenient Surface Mount Pin Lock Base that allows post replacement in 30 seconds. The surface mount posts can be installed on asphalt or concrete using epoxy kits, butyl pads or mechanical anchors

POST OPTIONS

- Standard post colors: white, yellow or orange
- Custom colors: light gray, dark gray, green, blue, black, brown or red
- Reflective sheeting: Standard is High Intensity Flexible Prismatic silver, amber or orange



BASE OPTIONS





Safe-Hit's flexible surface mount delineator posts come standard with a Surface Mount Pin Lock Base.

You may substitute with other bases.



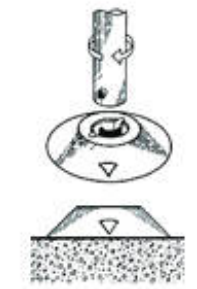
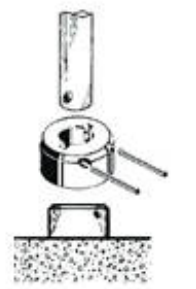

SAFE-HIT® ADHESIVES & ACCESSORIES

EPOXY KIT		BUTYL PAD
 <p>Epoxy Kit installs 1 base SHEPX13--KI Case Epoxy Kit installs 25 bases SHEPX25--CA Epoxy is also available in bulk 1 gallon and 5 gallon packaging</p>		 <p>Butyl Pad installs 1 base SHBTL23--KI Case Butyl Pads installs 40 units. SHBTL40--CA</p>
ADDITIONAL HARDWARE		
Lag Screws and Lag Anchors for asphalt	Lag Screws can be used as a semi-permanent method of mounting the Safe-Hit surface mount bases.	SHSMALAG--01
Hex Bolts and Drop-in Anchors for concrete	Bolts and Anchors can be used as a semi-permanent method of mounting the Safe-Hit surface mount bases.	SHSMADRI--01
Punch Pin Tool	For easy pin lock removal.	SHTOL----DRP

					
SMA	SLT	SST	SMT	RBM	PBS
Surface Mount Pin Lock Base	Sub-Level Twist Lock Base	Sub Surface Twist Lock Base	Surface Mount Twist Lock Base	Replaceable Barrier Marker	Portable Base
Ideal for permanent installations	Base leveled with the concrete or asphalt surface	Used for a low profile due to traffic	Ideal for periodic removal and installations	Can be mechanically fastened or glued to a barrier wall	No anchor or adhesive required Ideal for temporary applications
SHSMA-1---BL	SHSLT-1---BL	SHSST-1---BL	SHSMT-1---BL	SHRBM-1---BL	SHPSB-1---BL



SURFACE MOUNT ACCESSORIES	
	Oval Cap for Type 1 and Type 2 Posts. Available in black, white, yellow, dark gray, light gray, yellow-green.
	Round Cap
	Twist Lock Base Plug Available in black (BL), fl. orange (OR) and yellow (YL)



TWISTER® BASE PRODUCTS

SAFE-HIT TWISTER BASES AND ACCESSORIES

BASE DESCRIPTION	PART NUMBER	ROMACS
STR = Safe-Hit Twister 8" Base Kit	SHSTR-1---BL	617351B
Twister Threaded Pipe for Safe-Hit Post	612164B	612164B
Twister Plug	2021303-0000	114043B
Twister Anchor	ANC-SCR-3	603691B
Twister Anchor Epoxy Kit	617441B	617441B
Twister Anchor Epoxy Case (25 Kits)	617442B	617442B
Neoprene Locking Washer	118025B	118025B
Drop In Plastic Pipe Nub for Safe-Hit Post	617681B	617681B
Portable Base 32lbs (14"x30") NEW!	SRPCD-3---BL (Includes Rubber Mat, Twister Mounting Plate)	611309B
Portable Base 32lbs (PCD) Mat Only No Hardware	2714021-0000 (Includes Rubber Mat Only)	115672B
Twister Mounting Plate for Portable Base	2715094-0000	619516B

PORTABLE MAT

Recycled rubber mat with threaded receptacle to accept Twister pipe stub.
14" W x 30" L x 2" H 32 lbs.



DURA-POST TWISTER BASES AND ACCESSORIES

BASE DESCRIPTION	PART NUMBER	ROMACS
SMS = DuraPost Twister 8" Base Kit	SLSMS-3-PPBL	604950B
Twister Threaded Pipe for DuraPost	612163B	612163B
DuraPost Replacement Locking Pin	2714014-0000	116247B
Twister Plug	2021303-0000	114043B
Twister Anchor	ANC-SCR-3	603691B
Twister Anchor Epoxy Kit	617441B	617441B
Twister Anchor Epoxy Case (25 Kits)	617442B	617442B
Neoprene Locking Washer	118025B	118025B
Drop In Plastic Pipe Nub for DuraPost	617681B	617681B
Portable Base 32lbs (14"x30") NEW!	SRPCD-3---BL (Includes Rubber Mat, Twister Mounting Plate)	611309B
Portable Base 32lbs (PCD) Mat Only - No Hardware	2714021-0000 (Includes Rubber Mat Only)	115672B
Twister Mounting Plate for Portable Base	2715094-0000	619516B

DURA-POST® BASE PRODUCTS

TWISTER® DELINEATORS

The Twister™ is useful in applications where the delineator is to be placed and removed periodically. With its threaded mounting stem and anchor, the Twister can be easily placed into service using a standard philips screwdriver as a turning lever; no special wrench is required. The Twister mounting system is available in both our Safe-Hit® and Dura-Post® delineator product lines.

FEATURES & BENEFITS

- Threaded connection offers quick and easy delineator placement and removal.
- Available with 2-1/4" diameter Safe-Hit® standard performance delineators and 3" diameter Dura-Post high-performance delineator product lines.
- Anchor is placed easily in both asphalt and concrete.

TWISTER BASES CAN BE USED WITH PORTABLE MATS

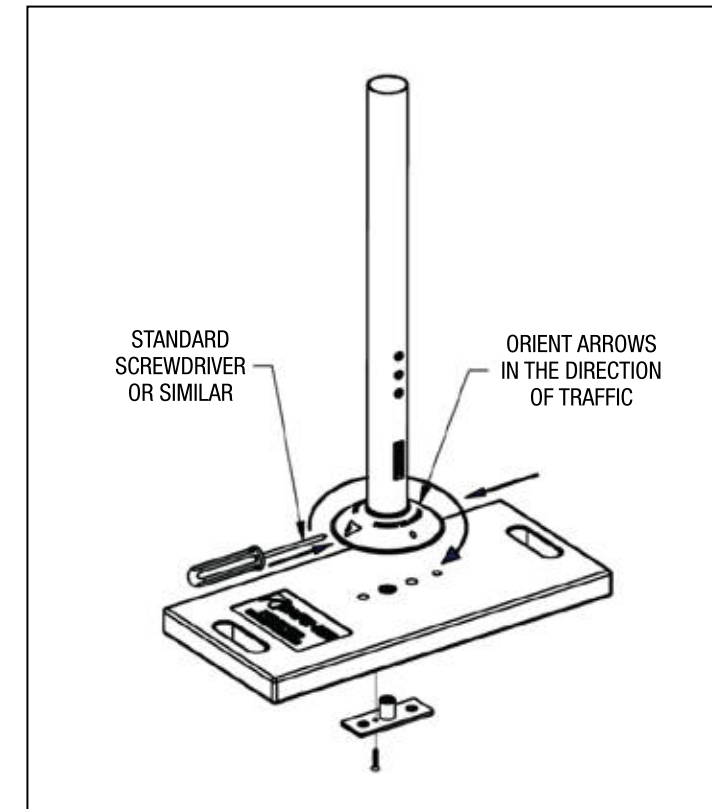

Dura-Post Twister 8" Base Kit
(Includes base, neo-lock-washer, threaded pipe and locking pin)



- 1 Neoprene Locking Washer
- 2 Twister Threaded Pipe
- 3 Twister Anchor



SAFE-HIT® SQR-LOC® FLEXIBLE DELINEATOR



Perfect for soil mount applications, the Safe-Hit® SQR-LOC® Flexible Delineator combines the proven, multiple hit performance of a Safe-Hit delineator with standard 2" perforated square tube anchors. The four-piece system consists of a post, anchor, collar and pin. The entire system is assembled and secured with a single push-in roll-pin making both assembly and maintenance quick and easy. The Safe-Hit SQR-LOC Flexible Delineator meets the requirements of NCHRP Report 350 Category 1 Device, and meets MUTCD 6F.80 requirements for delineator devices.

POST

Proven Safe-Hit Tube-in-Tube™ delineator technology.

- High quality impact performance including wheel-overs.
- Same familiar look as standard Safe-Hit delineators.
- New Cross-Crimp™ post snugly fits a wide range of anchor tolerances



SAFE-HIT® SQR-LOC® FLEXIBLE DELINEATOR

ANCHOR

Standard 2" Perforated Square Tube Anchor

- Easy to source sign post material.
- Enables direct replacement of existing installations that need repair.
- Uses standard square sign post driver tools.
- For soil or concrete applications.

COLLAR

8" Protective Collar will help:

- Protect the post from cutting during wheel over impacts.
- Reduce tire puncture hazard on the exposed anchor.
- Secure the retaining pin.
- Inhibit vegetation growth around the post.
- Provide impact protection from any direction.

ADDITIONAL FEATURES

- Ultra-violet (UV) resistant post.
- 360° visibility.
- Custom colors available.
- Lightweight, 4 piece self-righting delineator, self-locking system reduces assembly and maintenance efforts.
- Quick and easy removal and replacement if needed.
- Successfully tested to NTPEP Testing Standards.

Standard colors: white, yellow, orange.

Custom colors also available: green, red, blue, dark gray, light gray, black. Call for details.

Standard lengths: 48", 54", 60".

Custom lengths also available. Call for details.

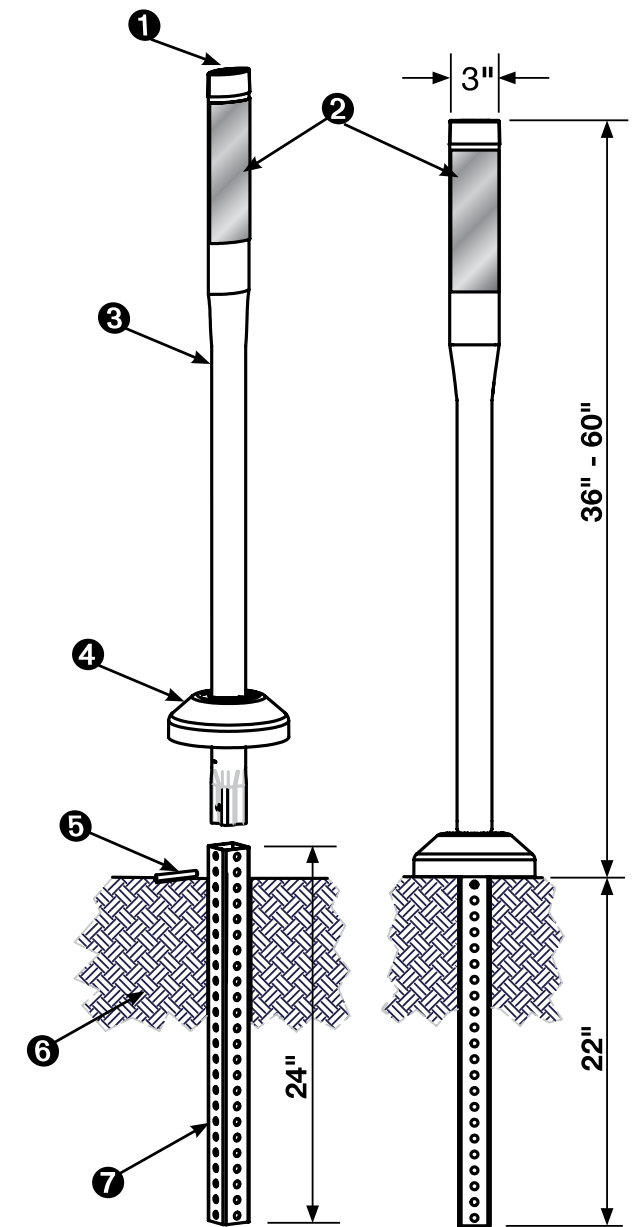

- 1 Cap
- 2 Prismatic Reflective Strip
- 3 SQR-LOC Delineator
- 4 Protective Collar
- 5 3/8" x 3" Slotted Spring Pin
- 6 Soil
- 7 2-0" x 2-0" x 24" 12 GA Perforated Tube



Dura-Post® High Performance Delineators, Channelizers & Markers



DURA-POST® HIGH PERFORMANCE SYSTEM

The Dura-Post® High Performance Delineator is an injection molded urethane flexible post that has been tested to withstand an extreme number of high speed impacts. It meets the requirements of NCHRP Report 350 Category 1 Devices, has been NTPEP tested and meets MUTCD Section 6F.63 + 6F.65 requirements for channelizing devices and tubular markers. Dura-Post is best utilized in locations with high speed/high impact frequency and is ideal for installation in construction zones, heavy traffic areas, bridges, and HOV/HOT demarcation.

FEATURES

- Tapered one piece urethane design.
- Extreme impact performance.
- 360° visibility
- Flexible at extreme temperatures.
- Standard post colors: white, yellow, orange.
- Standard reflective colors: silver, amber, orange.
- Custom post colors: blue, green, black, red, gray, yellow-green.
- High intensity, flexible prismatic reflective sheeting standard.
- Various lengths available

SPECIFICATIONS

- Up to 36" High
- 3" Post Diameter
- 2.11 lbs. (.95 kg)
- 8" Base Diameter

SURFACE MOUNT BASE

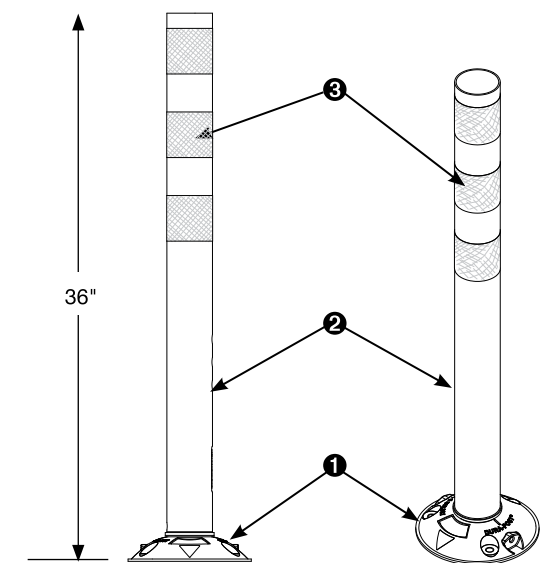

PART NAME	PART NO.
Base with Locking Pin (Secure to road surface with either screws or epoxy. Epoxy kit on page 7)	SLSMA-1---BL
3 Screws with Anchors for Asphalt/Concrete	618700
Soil Anchor	SLGPS-14---GL



- 1 8" diameter high impact Surface Mount Base
- 2 High impact performance, 3" diameter urethane tapered wall post
- 3 Reflective sheeting



DURA-POST® OPTIONS

DURA-POST® WITH REFLECTIVE BANDS		DURA-POST® WITH VERTICAL REFLECTIVE BANDS		DURA-POST® WITHOUT REFLECTIVE	
					
DESCRIPTION: Round 3" (76.2 mm) diameter 36" (914.4 mm) post with one, two or three high-intensity reflective bands for omni-directional reflectivity. Includes surface mount base or soil anchor.		DESCRIPTION: Round 3" (76.2 mm) diameter 36" (914.4 mm) post with 3" x 12" (76.2 mm x 304.8 mm) strip for directional reflectivity. Includes surface mount base or soil anchor.		DESCRIPTION: Round 3" (76.2 mm) diameter 36" (914.4 mm) post with no reflective material. Includes surface mount base or soil anchor.	
SURFACE MOUNT BASE OR SOIL ANCHOR **		SURFACE MOUNT BASE OR SOIL ANCHOR **		SURFACE MOUNT BASE OR SOIL ANCHOR **	
Post Color	One Reflective Band	Post Color	One Reflective Strip	Round Orange Posts	
ORANGE	SHL36SMA--O*-03	ORANGE	SHL36SMA--O*-12	SIZE	36"
WHITE	SHL36SMA--W*-03	WHITE	SHL36SMA--W*-12	COLOR	Orange
YELLOW	SHL36SMA--Y*-03	YELLOW	SHL36SMA--Y*-12	PART NO.	SHL36SMA--OX
	Two Reflective Bands		Two Reflective Strips	Round White Posts	
ORANGE	SHL36SMAE10*-03	ORANGE	SHL36SMAE10*-12	SIZE	36"
WHITE	SHL36SMAE1W*-03	WHITE	SHL36SMAE1W*-12	COLOR	White
YELLOW	SHL36SMAE1Y*-03	YELLOW	SHL36SMAE1Y*-12	PART NO.	SHL36SMA--WX
	Three Reflective Bands			Round Yellow Posts	
ORANGE	SHL36SMAE20*-03			SIZE	36"
WHITE	SHL36SMAE2W*-03			COLOR	Yellow
YELLOW	SHL36SMAE2Y*-03			PART NO.	SHL36SMA--YX

* Designate reflective color: S- Silver, A- Amber, O- Orange

** Must specify Surface Mount or Soil Anchor at time of order

DURA-POST® SX HIGH PERFORMANCE DELINEATOR

Dura-Post® SX High Performance Delineators are injection molded urethane flexible posts, used in conjunction with the Safe-Hit® post for added height. As with the Dura-Post, Dura-Post SX meets the requirements of NCHRP Report 350 Category 1 Devices and meets MUTCD Millennium Edition, Section 6F.55 requirements for channelizing devices.

Dura-Post SX high performance delineators are best utilized in locations with high speed/high impact frequency and ideal for installations in gore areas, fast curves, left turn lanes, HOV (High Occupancy Vehicle) lanes, or rail-way crossings.



FEATURES

- 360° visibility.
- Flexible at extreme temperatures.
- Used with either flat top or round Safe-Hit post.
- Abrasion resistant reflective sheeting.
- 8" diameter, high impact base.
- Standard post colors: white, yellow or orange.
- Standard reflective colors: silver, amber, orange.
- Various lengths available.

SPECIFICATIONS

- Up to 60" tall
- 3" Dura-Post SX diameter
- 2.25" inner post diameter

BASE & ANCHOR OPTIONS

- Asphalt
- Concrete
- Soil anchor
- Twister® Base for easy install and removal



SIZE	PART NO.
48" yellow flat top post with amber reflective	DSX4836YYFA043091
48" white round top post with silver reflective	DSX4836YYFA043091
48" orange round top post with silver reflective	DSX4836OORS048032
Many size, color and reflective combinations available. Call for details about your specific needs.	



DURA-POST® ANCHORS, BASES & ACCESSORIES

Dura-Post® flexible channelizers can be mounted on asphalt or concrete or anchored in soil. The Soil Anchor can be driven into the ground using the Manual Soil Anchor Driver or a power tool. The 8" (203.2 mm) anchor is recommended for concrete, the 14" (355.6 mm) and 18" (457.2 mm) anchors for normal soil and the 24" (609.6 mm) for loose or sandy soil.

SOIL ANCHORS

SIZE	PART NO.
14" 355.6 mm	SHL-GPS-14-GL
18" 457.2 mm	SHL-GPS-18-GL
24" 609.6 mm	SHL-GPS-24-GL



CONCRETE ANCHORS

SIZE	PART NO.
8" 203.2 mm	SLGPS-08--GL

SURFACE MOUNT BASE

SIZE	PART NO.
8" 203.2 mm	SLSMA-1---BL

The Surface Mount Base can be secured to the asphalt or concrete surface using an adhesive pad or epoxy kit.

BASE ADHESIVES

PART NAME	PART NO.
Epoxy Kit - Installs 1base	SHEPX-13-KI
Case Epoxy Kit - installs 25 bases	SHEPX-25-CA
Butyl Pad - Installs 1 base	SHBTL-23-KI
Case Butyl Pads - installs 40 units	SHBTL 40--CA

Epoxy is also available in bulk 1 gallon packaging



Surface Base Anchor



RUBBERTOUGH 360 (RT360)

SOIL ANCHOR SPIKE

Includes 3-1/2" (88.9 mm) sign post with hardware to attach a heavy-duty soil anchor spike. See page 5 for soil anchor installation tools.

SIZE	PART NO.	PANEL SIZE
36" 914.4 mm	SR936SMB32WXW	18" - 32" 457.2 mm - 812.2 mm
48" 1219 mm	SR948SMB44WXW	18" - 44" 457.2 mm - 1118 mm



BOLT-DOWN SURFACE MOUNT

Includes 3-1/2" (88.9 mm) sign post, single sided sign hardware, plastic base and connectors to attach post to base. Can be mounted to asphalt or concrete using galvanized steel self-tapping masonry screws.

SIZE	PART NO.	PANEL SIZE
36" 914.4 mm	SR936SMB32WXW	18" - 32" 457.2 mm - 812.2 mm
48" 1219 mm	SR948SMB44WXW	18" - 44" 457.2 mm - 1118 mm

PORTABLE MAT

Includes 3-1/2" (88.9 mm) sign post with single sided sign hardware and a 34" x 15" x 2-1/8" (863.6 mm x 381 mm x 56 mm), 32 lb (17.24 kg), recycled rubber mat with quick release hardware.

SIZE	PART NO.	PANEL SIZE
36" 914.4 mm	SR936PCD32WXW	18" - 32" 457.2 mm - 812.2 mm
48" 1219 mm	SR948PCD44WXW	18" - 44" 457.2 mm - 1118 mm



QUICK RELEASE PORTABLE BASE

Quick release mechanism requires no tools and makes set up and tear down simple.

PART NAME	PART NO.
Portable Base (14" x 30", 32 lbs.)	SRPCD-1---BL



VERTICAL SIGN PANELS

WHITE BLANK PANELS

White thick flexible panels with no reflective panels or decals applied. If you want to add your own reflective or decals, please follow the reflective or decal manufacturer's instructions for adhering their product to plastic panels to ensure high quality performance.

Panels come pre-punched with the hole & slot pattern to fit the Dura-Post® Vertical Panel Product System.

ORANGE/WHITE PANELS

High-Intensity Sheeting with 4" (101.6 mm) wide orange and silver diagonal stripes, sloping down either left or right.

YELLOW/BLACK PANELS

High-Intensity Sheeting with 4" (101.6 mm) wide yellow and black diagonal stripes, sloping down either left, right or chevron.

PEDESTRIAN CROSSING PANELS

High-Intensity Sheeting with high quality graphics and symbols professionally applied. All fluorescent yellow-green signs use diamond grade reflective sheeting.

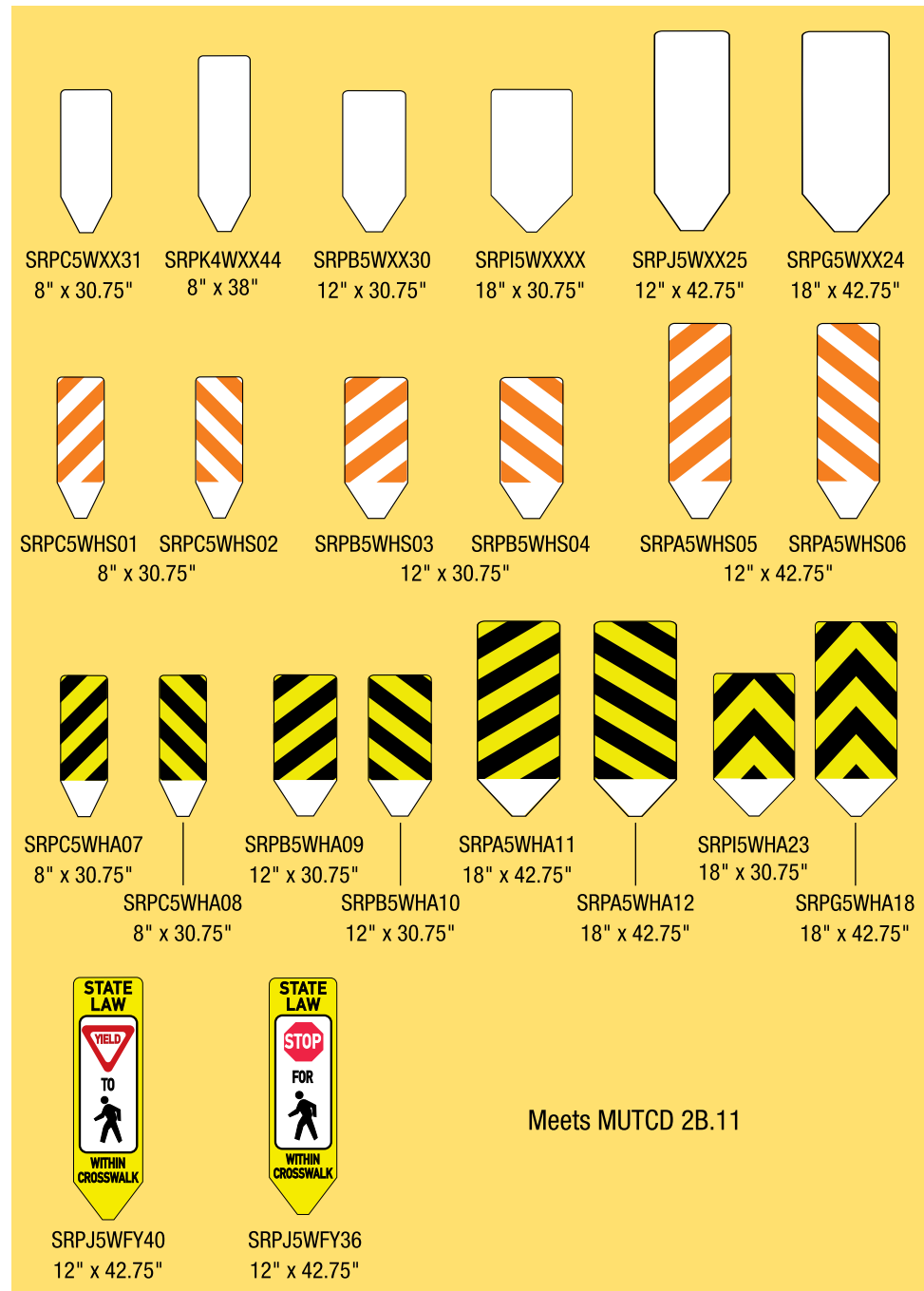

HIGH VISIBILITY MEDIAN MARKER

This 8" x 38" solid vertical panel is perfect for marking medians, islands or other similar obstacles. These panels are Type V Abrasion Resistant Reflecting Sheeting.

Available colors: silver, amber, red, orange, green and blue.

All sign post panels incorporate the Safe-Slot™ feature and meet the requirements of the MUTCD where applicable. Dura-Post® VP vertical panel sign post systems are available as completed ready to use panels, panel blanks, and reflectorized panels.



DURA-POST® VERTICAL SIGN PANELS



The Dura-Post® VP, High Performance Vertical Panel sign post system, is designed to meet the most demanding requirements for high visibility, reboundable, sign post systems. The Dura-Post VP sign post has been successfully tested to withstand 10 bumper hits, and wheel over impacts at 55 mph.

The Dura-Post VP sign post is also ideal for vertical panel applications such as Pedestrian Crossing Systems and Hazard Panels for both permanent and temporary applications.

FEATURES

- Stainless steel, locking sign panel fastening hardware.
- Surface Mount, Soil Anchor, and Portable Mat models available for use almost anywhere.
- Twister base option available for applications that require quick and frequent installation and removal.
- Standard colors: yellow, orange, white.
- Standard Heights: 36", 42", and 48"

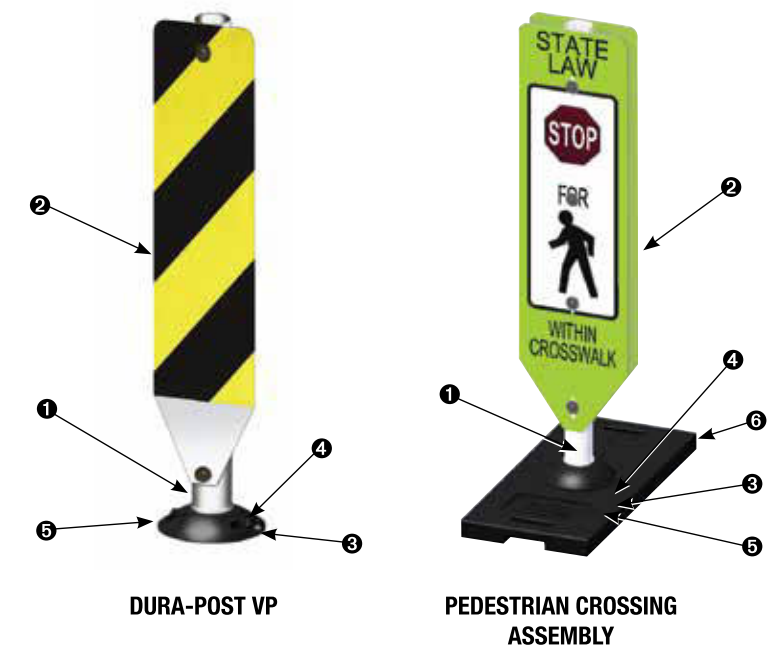











- 1 Dura-Post high performance post technology
- 2 Safe-Slot vertical panels
- 3 Stainless steel locking hardware
- 4 Pin lock surface mount base (Screw down and/or epoxy)
- 5 Twister Base
- 6 32 lb rubber mat (Optional with Twister Base) galvanized soil anchor available (Not pictured)



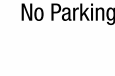

REFLECTIVE DECALS

Safe-Hit® and Dura-Post® and posts are available with decals and labels as an alternate choice to the standard reflective sheeting. A variety of special reflective arrangements, custom labels, and customer supplied labels and barricade tape can be applied upon request. Minimum quantities may apply.

PRODUCT NAME	DESCRIPTION	SIZE	PART NO.
  	Hazard - Right	Black/amber 3" x 12" 76.2mm x 304.8 mm Black/silver 3" x 12" 76.2mm x 304.8 mm Orange/silver 3" x 12" 76.2mm x 304.8 mm Red/silver 3" x 12" 76.2mm x 304.8 mm	SH-MD0036-R SH-MD0037-R SH-MD0038-R SH-MD0146-R
	Hazard - Left	Black/amber 3" x 12" 76.2mm x 304.8 mm Black/silver 3" x 12" 76.2mm x 304.8 mm Orange/silver 3" x 12" 76.2mm x 304.8 mm Red/silver 3" x 12" 76.2mm x 304.8 mm	SH-MD0036-L SH-MD0037-L SH-MD0038-L SH-MD0146-L
	Private Property Call Box - Right	Black/silver 3" x 12" 76.2mm x 304.8 mm	SH-MD0033
	Private Property Call Box - Left	Blue/silver - Rev. 3" x 12" 76.2mm x 304.8 mm	SH-MD0074-R
  	Call Box - Left	Blue/silver - Rev. 3" x 12" 76.2mm x 304.8 mm	SH-MD0074-L
	Call Box - Double	Blue/silver - Rev. 3" x 12" 76.2mm x 304.8 mm	SH-MD0074-D
	Reserved	Black/silver 3" x 12" 76.2mm x 304.8 mm Red/silver 3" x 12" 76.2mm x 304.8 mm	SH-MD0117 SH-MD0118
	No Parking Valet	Red/silver 3" x 12" 76.2mm x 304.8 mm Red/silver 3" x 12" 76.2mm x 304.8 mm	SH-MD0139 SH-MD0140
	  	No Park - Fire Lane	Black-Red/silver 3" x 9" 76.2mm x 228.6 mm
No Park - Tow Away		Black-Red/silver 3" x 9" 76.2mm x 228.6 mm	SH-MD0149
Fire Hydrant		Red-Blue/silver 3" x 9" 76.2mm x 228.6 mm	SH-MD0150
Mowing Limit	Brown/white - Rev. 2 1/2" x 6 1/2" 63.5mm x 165.1 mm	SH-MD0152	
Custom labels are available. Call for details!			

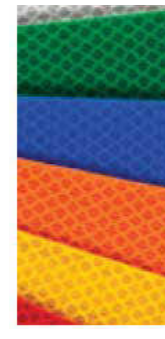
REFLECTIVE SHEETING

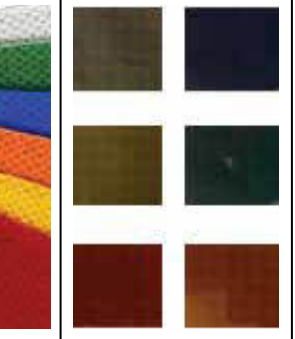
	High Intensity Flexible Prismatic	High Intensity Prismatic	Diamond Grade Cubed (DG3)	Diamond Grade VIP (Visual Impact Performance)	Abrasion Resistant	
						
	ASTM TYPE III	ASTM TYPE IV	ASTM TYPE XI	ASTM TYPE XI	ASTM TYPE V	
Available Colors (substitute color letter with asterisk () in part number)	S - Silver A - Amber O - Orange	S - Silver A - Amber O - Orange R - Red B - Blue G - Green	S - White A - Yellow R - Red B - Blue G - Green L - Fl. Yellow-Green Y - Fl. Yellow O - Fl. Orange	S - White A - Yellow Y - Fl. Yellow R - Red B - Blue G - Green	S - Silver A - Amber O - Orange R - Red B - Blue G - Green	
Size	†Line	Part Number	Part Number	Part Number	Part Number	
3" x 3"	SH,DP	SH-* H0303	SH-* P0303	SH-* D0303	SH-* Y0303	SH*A-03-0003
3" x 4"		SH-* H0304	SH-* P0304	SH-* D0304	SH-* V0304	SH*A-03-0004
3" x 6"		SH-* H0306	SH-* P0306	SH-* D0306	SH-* V0306	SH*A-03-0006
3" x 7.5"	SH	SH-* H0307.7	SH-* P0307.5	SH-* D0307.5	SH-* V0307.5	SH*A-03-07.5
3" x 9"		SH-* H0309	SH-* P0309	SH-* D0309	SH-* V0309	SH*A-03-0009
3" x 10"	DP	SH-* H0310	SH-* P0310	SH-* D0310	SH-* V0310	SH*A-03-0010
3" x 12"	RT360	SH-* H0312	SH-* P0312	SH-* D0312	SH-* V0312	SH*A-03-0012
4" x 7.5"	SH	SH-* H0407.5	SH-* P0407.5	SH-* D0407.5	SH-* V0407.5	SH*A-04-07.5
4" x 10"	DP	SH-* H0410	SH-* P0410	SH-* D0410	SH-* V0410	SH*A-04-0010
4" x 12"	RT360	SH-* H0412	SH-* P0412	SH-* D0412	SH-* V0412	SH*A-04-0012
6" x 7.5"	SH	SH-* H0607.5	SH-* P0607.5	SH-* D0607.5	SH-* V0607.5	SH*A-06-07.5
6" x 10"	DP	SH-* H0610	SH-* P0610	SH-* D0610	SH-* V0610	SH*A-06-0010
6" x 12"	RT360	SH-* H0612	SH-* P0612	SH-* D0612	SH-* V0612	SH*A-06-0012
9" x 7.5"	SH	SH-* H0907.5	SH-* P0907.5	SH-* D0907.5	SH-* V0907.5	SH*A-09-07.5
10" x 12"	RT360	SH-* H1012	SH-* P1012	SH-* D1012	SH-* V1012	SH*A-10-0012
12" x 7.5"	SH	SH-* H1207.5	SH-* P1207.5	SH-* D1207.5	SH-* V1207.5	SH*A-12-07.5

†Product Line Key: SH = Safe-Hit, DP = Dura-Post.

Note: Other sizes available. Call for details.



Specialty Products

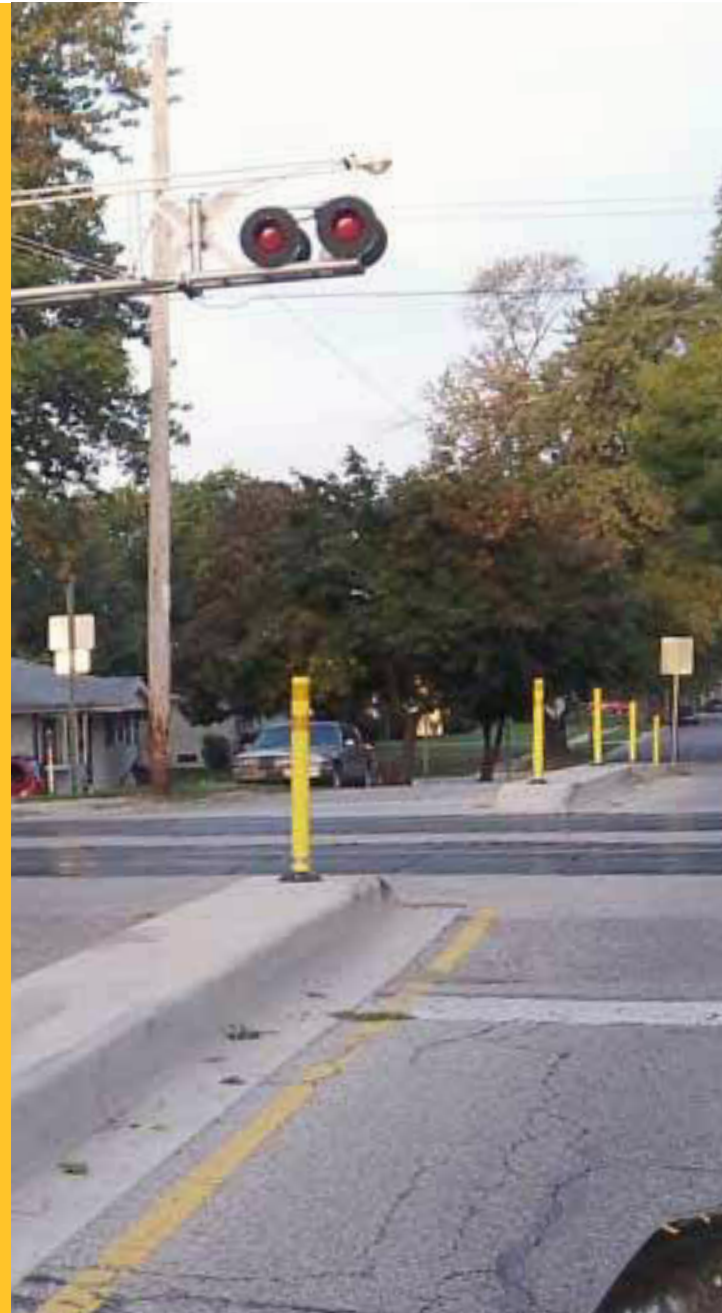

SAFE-HIT® SIGN POSTS

FLEXIBLE SIGN SYSTEMS

Safe-Hit's® flexible sign posts and signs are made of durable plastic and are tested to withstand vehicular impacts. Each sign post is provided with internal sign mounting hardware, as well as screws and washers for mounting signs. Sign Posts are available to fit all Safe-Hit bases and anchors.



Standard post colors: white, yellow, orange
 Custom post colors: gray, green, blue, black, brown, red.

Full list of stocked signs, sign blanks and custom signs available upon request.

SAFE-HIT® FLEXIBLE SIGN POSTS		
Soil Anchor	48" (1219 mm) round post with built-in sign hardware, mounting screws and 18" (457.2 mm) Drivable Soil Anchor (GP3).	SX348GP318WX SX348GP324WX
Surface Mount	48" (1219 mm) round post with built-in sign hardware, mounting screws and Surface Mount Pin Lock Base (SMA)	SX348SMA18WX SX348SMA24WX
Portable	48" (1219 mm) round post with built-in sign hardware, mounting screws and portable 18 lb. (8.16 kg) Rubber Base (PSB).	SX348PSB18WX SX348PSB24WX
"Double sided hardware: SX348GP324WX-D" applies to all.		



SAFE-HIT® SNO-POST™ BOUNDARY MARKER

The Safe-Hit® Sno-Post™ Boundary Marker is an efficient, affordable replacement for traditional snow posts, painted wooden sticks, skinny fiber poles or expensive delineator posts. The marker is made of 3 simple components - a 36" post constructed of flexible, durable polyethylene with ultraviolet inhibitors, a 12" anchor made of high impact polystyrene, and one of numerous fastener options.



SPECIFICATIONS

- 36" tall post, 3" reflector
- Available in 2 diameters
 - 1.75" (medium) black
 - 2.25" (large) multiple colors

12" PLASTIC ANCHOR

- High impact polymer
- Structural support fins
- Easy to drive

NUMEROUS FASTENER OPTIONS

- Tie wrap (standard)
- Push pins
- Galvanized or stainless roll pin
- Galvanized or stainless nut & bolt

OTHER APPLICATIONS

- Utility markers
- Fire hydrant markers
- Distance markers
- Drain & culvert markers
- Walking trail & campsite markers



- 1 Cap (Optional)
- 2 Reflective sheeting
- 3 36" polyethylene post
- 4 12" High impact polyethylene anchor
- 5 Fastener (Tie wrap)

SAFE-HIT® SNO-POST™ BOUNDARY MARKER

Medium	36"	1.75" Black
Large	36"	2.25" Multiple Colors

SAFE-HIT® CERTIFIED AIRPORT MARKERS

Consists of co-extruded polyethylene tube with ultraviolet inhibitors, high strength plastic fasteners, and Type IV retro-reflective sheeting. It has been tested and certified by ETL to the Federal Aviation Administration (FAA) L-853 standards of the FAA Advisory Circular: 150/5345-39D. The Safe-Hit Airport Marker is ideal for installations on airport taxiways, airport runway edges, ends, and thresholds.



FEATURES

- No above ground metal parts.
- 360° visibility
- Corrosion resistant soil anchor with integrated locking tabs for quick, easy marker placement.
- Reflective color choices: blue, red, green, silver.
- Debris inhibiting plastic cap.
- Optional anti-perch bird cap available.
- Surface mount or soil anchor versions available.

SPECIFICATIONS

- 14" (356 mm), 18" (457 mm), 24" (610 mm), 30" (763 mm) tall
- 8" (203 mm) base diameter
- 18" (457 mm) standard soil anchor length
- 96 sq. inches of ASTM D4956 Type IV flexible diamond grade reflective sheeting

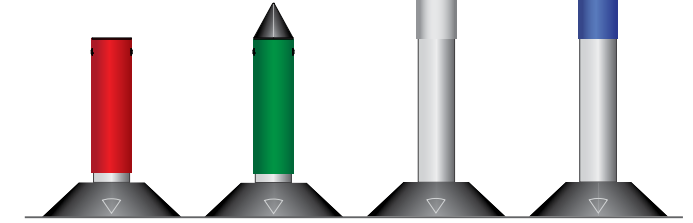

AIRPORT MARKER BASE OPTIONS

See page 6 for additional information.

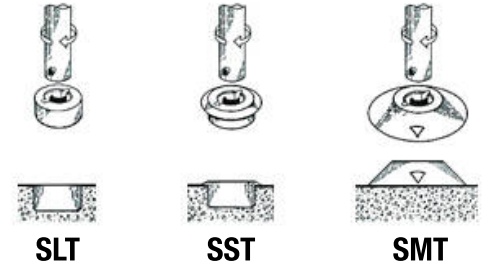

SAFE-HIT® CERTIFIED AIRPORT MARKERS

		SURFACE MOUNT	SOIL MOUNT	
Taxiway Marker (Blue)	14"	SH614SMA--WB-12	SH614GP5--WB-12	<ul style="list-style-type: none"> • For the optional anti-perch bird cap add a "C" to the end of the part number. • For Surface Mount Twist Lock Base substitute "SMT" for "SMA". • For Sub-Surface Mount Twist Lock Base substitute "SST" for "SMA". • For Sub-Level Surface Mount Twist Lock Base substitute "SLT" for "SMA". • Other soil anchor lengths available to match your particular soil conditions.
	18"	SH618SMA--WB-14	SH618GP5--WB-14	
	24"	SH624SMA--WB-14	SH624GP5--WB-14	
	30"	SH630SMA--WB-14	SH630GP5--WB-14	
Runway Edge Marker (White)	14"	SH614SMA--WS-12	SH614GP5--WS-12	
	18"	SH618SMA--WS-14	SH618GP5--WS-14	
	24"	SH624SMA--WS-14	SH624GP5--WS-14	
	30"	SH630SMA--WS-14	SH630GP5--WS-14	
Runway Threshold Marker (Green)	14"	SH614SMA--WG-12	SH614GP5--WG-12	
	18"	SH618SMA--WG-14	SH618GP5--WG-14	
	24"	SH624SMA--WG-14	SH624GP5--WG-14	
	14"	SH630SMA--WG-14	SH630GP5--WG-14	
Runway End Marker (Red)	14"	SH614SMA--WR-12	SH614GP5--WR-12	
	18"	SH618SMA--WR-14	SH618GP5--WR-14	
	24"	SH624SMA--WR-14	SH624GP5--WR-14	
	30"	SH630SMA--WR-14	SH630GP5--WR-14	



SAFE-HIT® GUARDRAIL DELINEATORS

Guardrail delineators are highly visible, reflective devices mounted directly to the guardrail structure. They enhance both day and night delineation. Posts include appropriate hardware for installation to wood or steel posts.

WOOD POSTS

Post flattened on top with one 3" x 9" (76.2 mm x 228.6 mm) reflective strip; includes two aluminum nails for attaching to wood guardrail posts.



STEEL POSTS

Post flattened on top with one 3" x 9" (76.2 mm x 228.6 mm) reflective strip; includes two self-tapping screws for attaching to steel guardrail posts.

TYPE	SIZE	PART NO.
Wood Posts	27"	SH227GRD--WS
Steel Posts	27"	SH227GRS--WS

BARRIER MARKERS

Used to delineate Jersey Barrier and can be used as a mile marker, drain marker or other type of marker.

COLOR	SIZE	PART NO.
Yellow	16"	SH216RBM--YA
	24"	SH224RBM--YA
White	16"	SH216RBM--WS
	24"	SH224RBM--WS



DURA-POST® GUARDRAIL DELINEATORS

Use the Dura-Post® guardrail delineator in applications that could be frequently impacted or are in extreme environments. All 3" round Dura-Post guardrail delineators come with a steel guardrail mounting tube, self-tapping screws for wood or steel guardrail posts, and delineator fasteners. Custom heights up to 36" and other colors such as orange are available.

TYPE	SIZE	PART NO.
With 3" x 9" silver high intensity flexible prismatic reflective	24" 609.6 mm	SHL24GRS--WS-09
With 3" x 9" amber high intensity flexible prismatic reflective	24" 609.6 mm	SHL24GRS--YA-09



KONAPOST® QUICK CHANGE DELINEATORS

The KonaPost® delineator is an excellent alternative to traditional orange cones. It is ideal for reoccurring applications where orange cones or markers are often impacted and must be quickly deployed in specific patterns on a regular basis. The unique system of the KonaPost delineator enables it to take multiple impacts and stay in place.



It has been tested to take over 200 direct wheel impacts at 45 mph. The flexible 6" plug easily inserts into a hot-dip galvanized steel receptacle that is recessed into the pavement. The delineator posts can be deployed when needed and quickly removed by lifting them out of the pavement receptacles.



APPLICATIONS

- Gate closures
- Reversible lanes
- Lane redirect
- Parking lots & garages
- Event management

FEATURES

- Extremely impact resistant.
- 360° full visibility.
- No protruding metal parts.
- One piece post construction.
- Withstands extreme temperatures.
- Reflective sheeting available.
- Available in white, yellow, orange or custom colors.

SPECIFICATIONS

- Height (Post) 19" (483 mm)
- Diameter (Post) 4" (102 mm)
- Height (Plug) 6" (152 mm)
- Width (Receptacle plate) 4.5" (114 mm)
- Depth Receptacle 8" (203 mm)

RECEPTACLE	SIZE	PART NO.
603667	4" x 19"	SHLG19GPR--YX (Yellow)
8" depth	w/6" plug	SHLG19GPR--OX (Orange)
4-1/2"x 4-1/2" flange		SHLG19GPR--WX (White)



DURA-POST® ISLAND K-MARKERS

K-MARKER

3" x 18" (76.2 mm x 457.2 mm) post with a 15" x 6" (381 mm x 152.4 mm) target plate attached with one 12" x 6" (304.8 mm x 152.4 mm) reflective strip on front, two 1" x 6" (25.4 mm x 152.4 mm) patches.

PART NAME	PART NO.
18" 457.2 mm	SHLK18SMAWA-03



SAFE-HIT® ISLAND K-MARKERS

Island markers are ideal for delineating traffic islands, entryways or wherever special markers are needed. All are available in surface and soil mount versions.

K-MARKER SURFACE MOUNT

Round white post, with 15" x 6" (381 mm x 152.4 mm) target plate attached with one 12" x 6" (304.8 mm x 152.4 mm) reflective strip on front, two 1" x 6" (25.4 mm x 152.4 mm) patches on back and a 6" (152.4 mm) wrap around post. Includes surface mount pin lock base.



K-MARKER SOIL ANCHOR

Round white post, with 15" x 6" (381 mm x 152.4 mm) target plate attached with one 12" x 6" (304.8 mm x 152.4 mm) reflective strip on front, two 1" x 6" (25.4 mm x 152.4 mm) patches on back and 6" (152.4 mm) wrap around post. Includes drivable soil anchor.



BASE OPTIONS

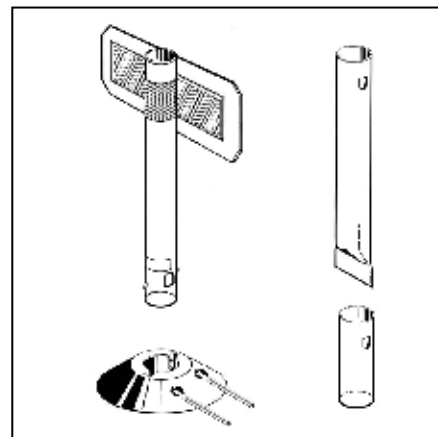

TYPE	SIZE	PART NO.
Surface Mount	18"	SH718SMA-WA
	24"	SH724SMA-WA
Soil Anchor	18"	SH718GP3-WA
	24"	SH724GP3-WA

SPEED BUMPS AND PARKING STOPS

Reduce traffic to a safe speed with our highly visible solid plastic speed bumps and replace broken and unsightly concrete parking blocks with the Parking Stop. Made from 100% recycled plastic, these products will never erode or lose their color.



FEATURES

- 100% recycled plastic
- 20% the weight of concrete
- Easy one person installation
- Maintenance free (never needs painting)
- Superior strength and durability

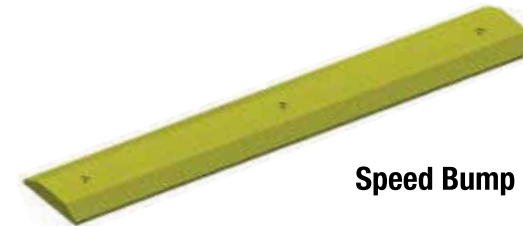

Speed Bump



Parking Stops

SPEED BUMP ASSEMBLY (Hardware included)

COLOR	SIZE	PART NO.
Yellow	6'	617659

SPEED BUMP ONLY (No hardware)

COLOR	SIZE	PART NO.
Yellow	6'	113803

PARKING STOP ASSEMBLIES (Hardware included)

COLOR	SIZE	PART NO.
Yellow	4'	617655
Yellow	6'	617656
Blue	6'	617657
Grey	6'	617658

PARKING STOP (No hardware)

COLOR	SIZE	PART NO.
Yellow	4'	117502
Yellow	6'	117503
Blue	6'	117499
Grey	6'	117501

REPLACEMENT HARDWARE

NAME	PART NO.
Replacement Hardware Kit for 4' Parking Stop	618841
Replacement Hardware Kit for 6' Parking Stop & 6' Speed Bump	618840



SAFE-HIT® SPECIALTY MARKERS

FIRE HYDRANT MARKERS

Helps fire department personnel quickly locate hydrants during heavy snow or when hydrants are located in tall vegetation areas. They also help reduce the risk of damage during snow plowing operations. The flexible post does not obstruct access to the hydrant.

COLOR	SIZE	TYPE	PART NO.
Yellow	48"	w/Mounting Bracket	SH248FHM--UL
	48"	Soil Anchor	SH248GP3--UL
White	48"	Surface Mount Base	SH248SMA--UL
	3" x 12"	Extra FHM Decal	SH-MD0150



SAFE-HIT® GLARESCREEN

The Safe-Hit® GlareScreen is a reboundable vertical delineator blade system that is used to delineate both temporary and permanent medians and block out headlight glare of oncoming traffic. Positioned on the top of median barriers, this delineator system helps to minimize traffic slowdowns in work zone areas. Made of polymeric materials, the blades are flexible and durable, and can take multiple high speed impacts and return to vertical.



SPECIFICATIONS

MOUNTING BASE

- 4-3/4" diameter x 1-7/8" tall
- Black high-impact polymer

FULL BASE RAIL SECTION

- 5-1/2" x 24" x 5/8"
- White high-impact polymer

HALF BASE RAIL SECTION

- 5-1/2" x 11" x 5/8"
- White high-impact polymer

BLADES

- Green, orange & white
- 9" x 18", 9" x 24" or 9" x 30"
- High-impact polymer with radius corners



SAFE-HIT® GlareScreen Replacement Blades		
Green	9" x 18"	SHGSP-18---G
	9" x 24"	SHGSP-24---G
	9" x 30"	SHGSP-30---G
White	9" x 18"	SHGSP-18---W
	9" x 24"	SHGSP-24---W
	9" x 30"	SHGSP-30---W
Orange	9" x 18"	SHGSP-18---O
	9" x 24"	SHGSP-24---O
	9" x 30"	SHGSP-30---O

Features

- Blocks out headlight glare.
- May serve as a delineator when reflective sheeting is added to provide visibility and traffic channelization.
- Reboundable and durable. Designed to help withstand multiple impacts from overhanging loads.
- Helps to reduce congestion in work zones by limiting cross-median visibility.
- Versatile, modular design adapts to most sizes of temporary or permanent barrier.
- Blade installation and replacement with two retaining pins instead of bolts or screws.
- Removable blade allows access to both sides of highway for maintenance or emergency crews.
- Ideally suited for construction work zones and curved roadways.
- Less debris when impacted compared to fencing or plywood products.
- Standard green color. Custom orange or white colors available.
- Standard height 18" (457 mm), 24" (610 mm) and 30" (762 mm).
- Compact storage and shipping means more feet per delivered load.

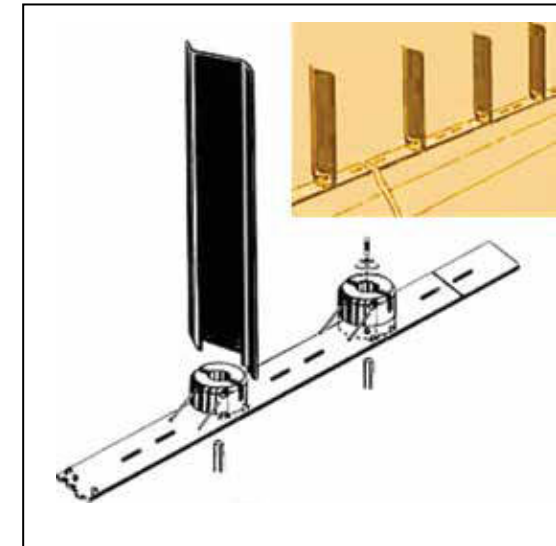

Modular System



- ❶ Retroreflective Sheeting (Optional)
- ❷ Flexible, High-Impact Polymer Blade (18", 24" or 30" tall)
- ❸ Zinc Plated, Galvanized or Stainless Steel Hardware
- ❹ Black High-Impact Mounting Base
- ❺ 24" and 11" Modular Base Rail Sections

SAFE-HIT GLARESCREEN HARDWARE



Base & Retaining Pins



Hardware

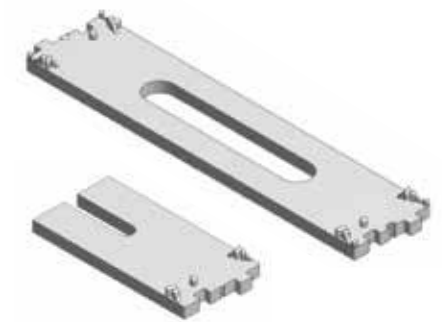

24" & 11" Base Rail Segments



